

FLOOR DOOR

Side B	Side C	Side D	VERSION	H LIGHT	H FRAME	FRAME	WINDOW	GLASS	ACCESSORIES
		G 1	Alluminium	2000	2100	Anodized aluminium	Panoramic	<u>Satinato</u>	C2

C1 = Enabling key for the floor button pad (single insertion) C2 = Enabling key for the floor button pad (double insertion) PM = Button pad on the wall PE = Outside lock and button pad

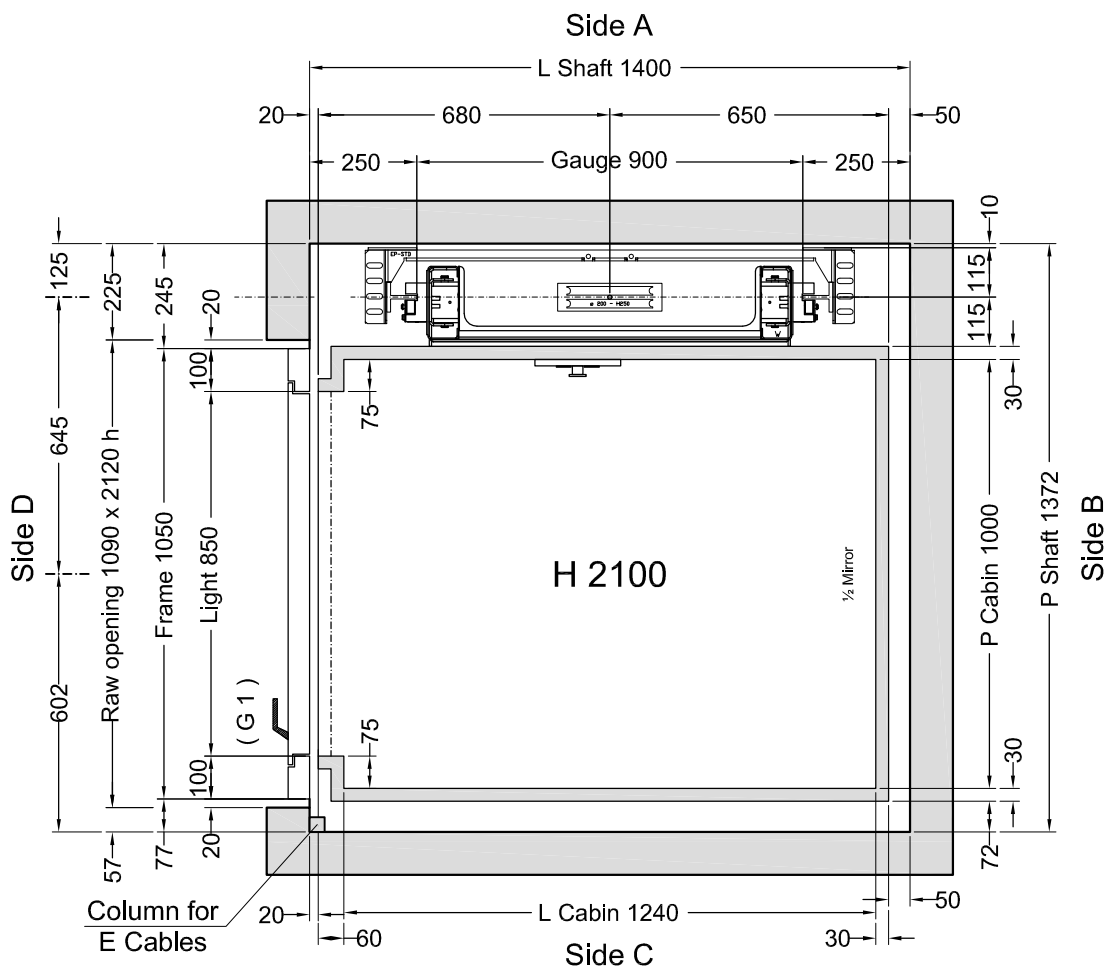

Stops: 2 - Doors: 2

Shaft in **Masonry (Muratura)**

Customer own flooring: Dimensions **1270 (L) x 1000 (P)** thks **20 mm** Weight: **50 kg**

ORDER 94045 - Brisbane ORDER NUMBER PS2105	VERSIONS	Description	Designer	Date	Final Drawings	
		Correzione: pulsanti Blue.	L. Del Bianco	31/08/2015	Model ELFO	SHEET 1/2
		L vano da 1419 a 1400; L cabina da 1260 a 1240.	D.Tomei	06/08/2015		SHEET DIMENS. A3
		Varie modifiche.	L. Del Bianco	03/08/2015		SCALE 1:12.5
CLIENT Lift Shop PLACE OF INSTALLATION 19 Batman Street, Clayfield, Qld		Final Drawings L. Del Bianco	1° STESURA 31/08/15	CAPACITY 300 kg		AREA m² 1,24 CAPACITY



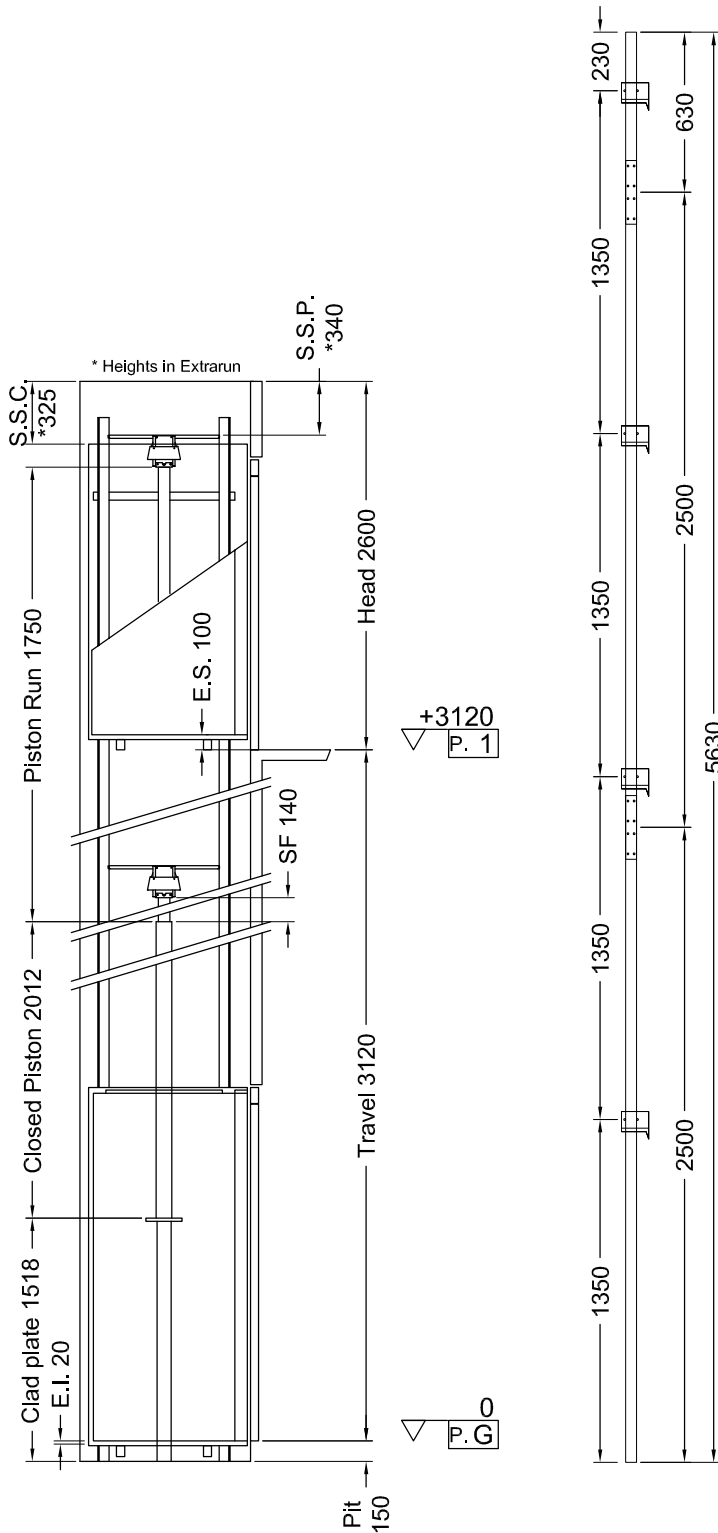

Indirect Installation Speed 0,3 m/s 31/08/15 10.27 (V.2852)

THRUST DURING NORMAL OPERATION			THRUST OF SAFETY DEVICE INTERVENT.		
P	(N)	10890	P	(N)	481
N	(N)	556	N	(N)	7336
F1	(N)	1371	F1	(N)	2285
F2	(N)	286	F2	(N)	477

SPACES		PRESSURES		
E.I.	Extrarun below cabin (mm)	20	Max static pressure (bar)	36,12
E.S.	Extrarun above cabin (mm)	100	Min static pressure (bar)	20,83
SF.	Piston extraction (mm)	140	Overpressure limit (bar)	50,57
S.S.P.	Piston/head (mm)	340	Residual pressure (bar)	1,25
S.S.C.	Cabin/head (mm)	325		

HYDRAULIC UNIT		MECHANICAL PARTS	
Central unit	GMV HL 3010 (-*)		
Capacity (l/min)	35	Guide rails	70x70x9
Motor (V)	MF230V	Brackets	(Nr) 4
Power (Kw)	2,9	Ropes	Ø 9 mm 6-(1+9+9)
Nominal current (A)	27	Cables length (mm) 2 x	9000
Piston	Start Home (Ø)70x5x1750	Min actual breaking load (N)	47300
Opt. oil position	BASSO		
Tubing	3/4" EN 853 1SN - FD 3/4" - GOMITO 3/4"		
Tubing length (mm)	7000		
Min hydraulic oil (L)	39		

SECURITY DEVICES	Manufacturer	Model	Certificate
Safety Gear	PFB	BP1	TÜV AFV515
Block Valve	START ELEVATOR	1/2" 0327	CA50.00525
Key Locks	Prudhomme	PLT/L/CPX NL 11-400-1002-125-02	

MACHINERY LOCATION			
At floor	G	Length of the hose travel	3000 (mm)
Cables enter in shaft: Side	A		

CABIN		CABIN ACCESSORIES	
Panels	Similinox F12PPS	½ Mirror	Side B
Finishes	Inox BA mecc.	Outside covering	Roof
Oper. panel	VERTICAL (Like finishes)	Outside finishing	Similinox F12PPS
Floor	By Customer		
Ceiling	SPOTS LED - Similinox F12PPS		

- OTHER ACCESSORIES**
- Guides dimension 2.5 m
 - Manual pump
 - Manostat with overweight signal
 - Two speed
 - Handles CASPIM (Long)
 - Telephone by Lift Shop
 - Cabinet: Blu Stellato B41SMM
 - Full height Infra-red curtain V2
 - Roof covering
 - Automatic Control 2011
 - Blue Buttons
 - Cabin Buttons: G 1
 - Call Accept
 - Emergency manual descent from cabin



ORDER
94045 - Brisbane

ORDER NUMBER
PS2105

CLIENT
Lift Shop

PLACE OF INSTALLATION
19 Batman Street, Clayfield, Qld

Final Drawings
L. Del Bianco

Final Drawings

SCALE
OUT OF SCALE

1° STESURA
31/08/15

SHEET
2/2