

LIFTSHOP
ELEVATOR BOUTIQUE



life with style



Q1

Made in the UK

8 Reasons why to choose Lift Shop

01

CERTAINTY

A showroom visit lets you experience the lift before you own it.

Showroom visits are essential to help you learn and experience the proposed lift system.

Informed and educated purchasers usually select the best.
So research your many options carefully.

02

THE SAFEST LIFTS

The only lifts to include “in-cabin self-rescue” feature.

24/7 call centre assistance.

Fully code compliant.

Full height infra-red light ray curtains.

Auto lower and unlocks in the event of a power failure.

05

UNBEATABLE VALUE

Our formula is:

Lifts – proven long history, stable and secure manufacturer, ultra-reliable premium quality.

Volumes – Lift Shop sells more lifts than any other Australian home lift specialist.

Costs – Annual costs shared by 5 offices, 700+ new lift clients, and thousands of routine service clients.

We do not have hidden extras.

06

A GENUINELY GREAT REPUTATION

Check Google Reviews and sites like productreview.com.au

100's of genuine, original testimonials from real clients can be read in our showroom's.

Independent awards and recognition.

03

THE LEADER FOR TECHNOLOGY

2 speed drives for maximum speed with smooth acceleration.

Computer monitoring of the latest lift functions for efficient diagnosis and repair.

Sized to suit, and styled to suit, has always been the Lift Shop advantage and the big difference from others.

04

SUPPORT & FREE INCLUSIONS

After your order is placed we have full time and dedicated, Construction Support, Site Managers, and Installation Teams to ensure your lift is built on time and budget.

The Lift Shop team is coordinated by our custom database which tracks everything. We are the experienced and proven solution for a stress-free delivery of your lift.

07

LOW SERVICE COSTS

Lift Shop only services and maintains its own quality lifts with full technical support/spares in Australia.

Other companies lifts distract from the attention good clients deserve.

We focus on you.

08

THE NO.1 HOME LIFT SPECIALIST

We are Australia's largest lift company.

The undisputed leader in Italian elevators.





UK made - Q1

Why It's Awesome

- Quick supply and installation
- Faster than the competition
- Great value and a low price
- Minimal building works required (just a hole in the floor)
- Small footprint and self contained system means no shaft space
- Low power consumption
- A compact and elegant solution
- Made in the United Kingdom
- The safest compact lift on the market







Q1

Lift Sizes	Small 542mm x 750mm	Medium 850mm x 750mm	Large 850mm x 1250mm
Cutout size	755mm x 1085mm	1062mm x 1085mm	1062mm x 1585mm
Speed	0.08m/s / 0.15m/s (Fast)		
Opening	Single		
Max travel	4200mm - 2 floors		
Persons load	255kg (3 persons)		
Finish	RAL Powdercoat 7035		
Lighting	LED		
Control buttons	2 remote's		
Vision panels	Perspex		
Rails	Aluminium		
Flooring	Vinyl - Mottled Battle Ship		
Phone	Black Handset		
Control panel	Black Vertical		
Rear cladding	RAL Powdercoat 7042		
Cabin height	1900mm		
Pit	No pit required		
Headroom	2400mm (for slow speed - 0.08m/s) 2500mm (for fast speed - 0.15m/s)		
Compliance	European and Australian EN81-41		
Safety	Numerous safety features		



Q1 - Custom Options

- Special custom RAL colours
-

- Mirror in fill panels
-

- Handrail
-

- Tip-up seat
-

- Power operated door
-

- Auto dialer
-

- LED display panel
-

- Mood lighting
-

- Blue tooth activation
-

- Upgraded flooring

layout drawings

Plan View

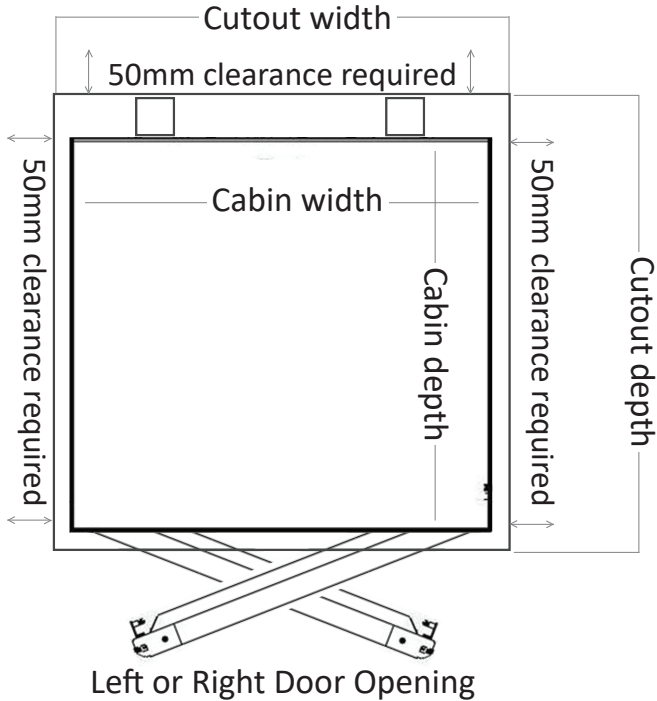

	Small	Medium	Large
Cabin width	542mm	850mm	850mm
Cabin depth	750mm	750mm	1250mm
Cutout width	755mm	1062mm	1062mm
Cutout depth	1085mm	1085mm	1585mm

Top Floor Section View

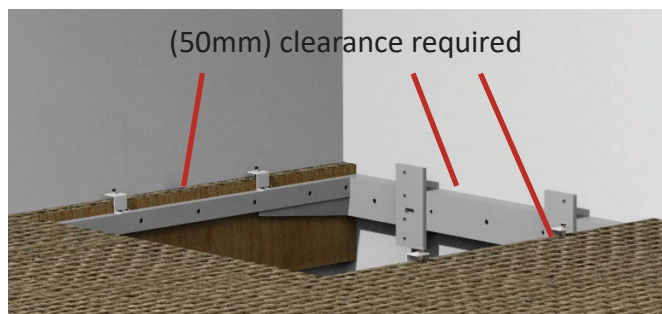
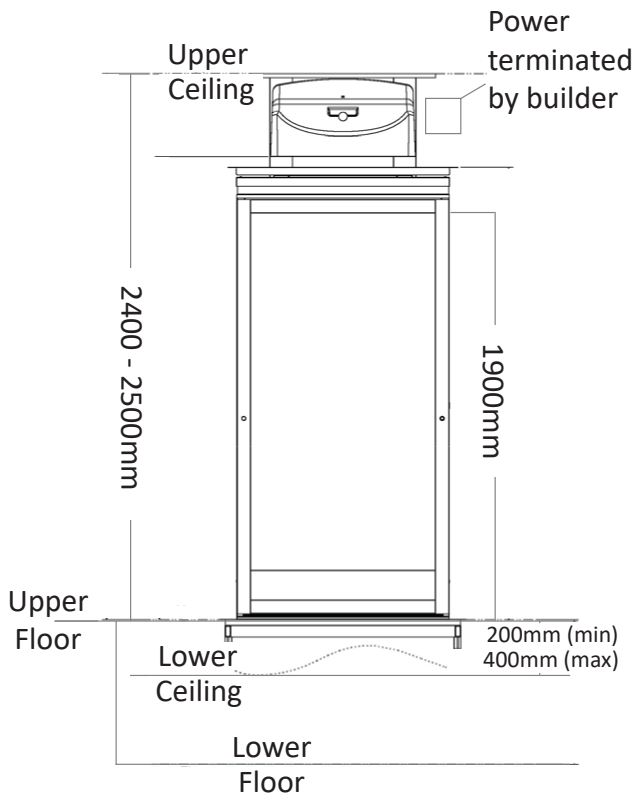

sketch

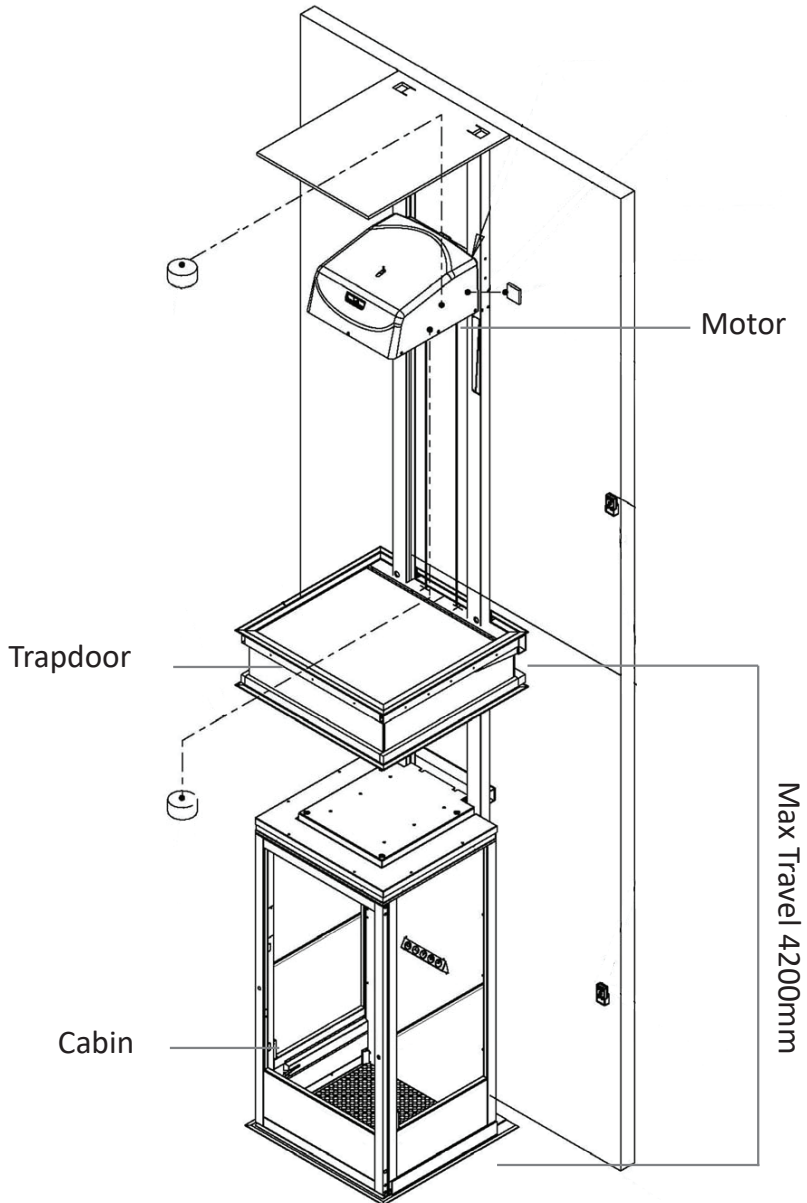

finishes

Lift Colours



Clear Perspex

Flooring



Vinyl - Battleship



RAL
Powdercoated



Vinyl - Light Oak



Vinyl - Marble Mist



SYDNEY

1/75 Corish Circle
Eastgardens NSW 2036
T 02 9666 3939



MELBOURNE

1/1 Belgium Avenue
Richmond VIC 3121
T 03 9421 4222



BRISBANE

4/300 Cullen Avenue East
Eagle Farm QLD 4009
T 07 3014 0633



PERTH

15/75 Robinson Avenue
Belmont WA 6104
T 08 9460 0666



LOS ANGELES

Pacific Design Center
Blue Building - Suite B-110
8687 Melrose Avenue
West Hollywood CA 90069
T 855 326 8847

liftshop.com.au
1800 440 714

Awesome